



The Best Equipment Adapts to Your Needs

Rosenbauer FX body styles feature a wide range of compartment configurations so that you can build the truck you want. Rosenbauer also provides a wide assortment of shelves, roll-out trays and equipment mounting provisions to keep all your equipment organized for easy access.



ROSENBAUER
FX BODY

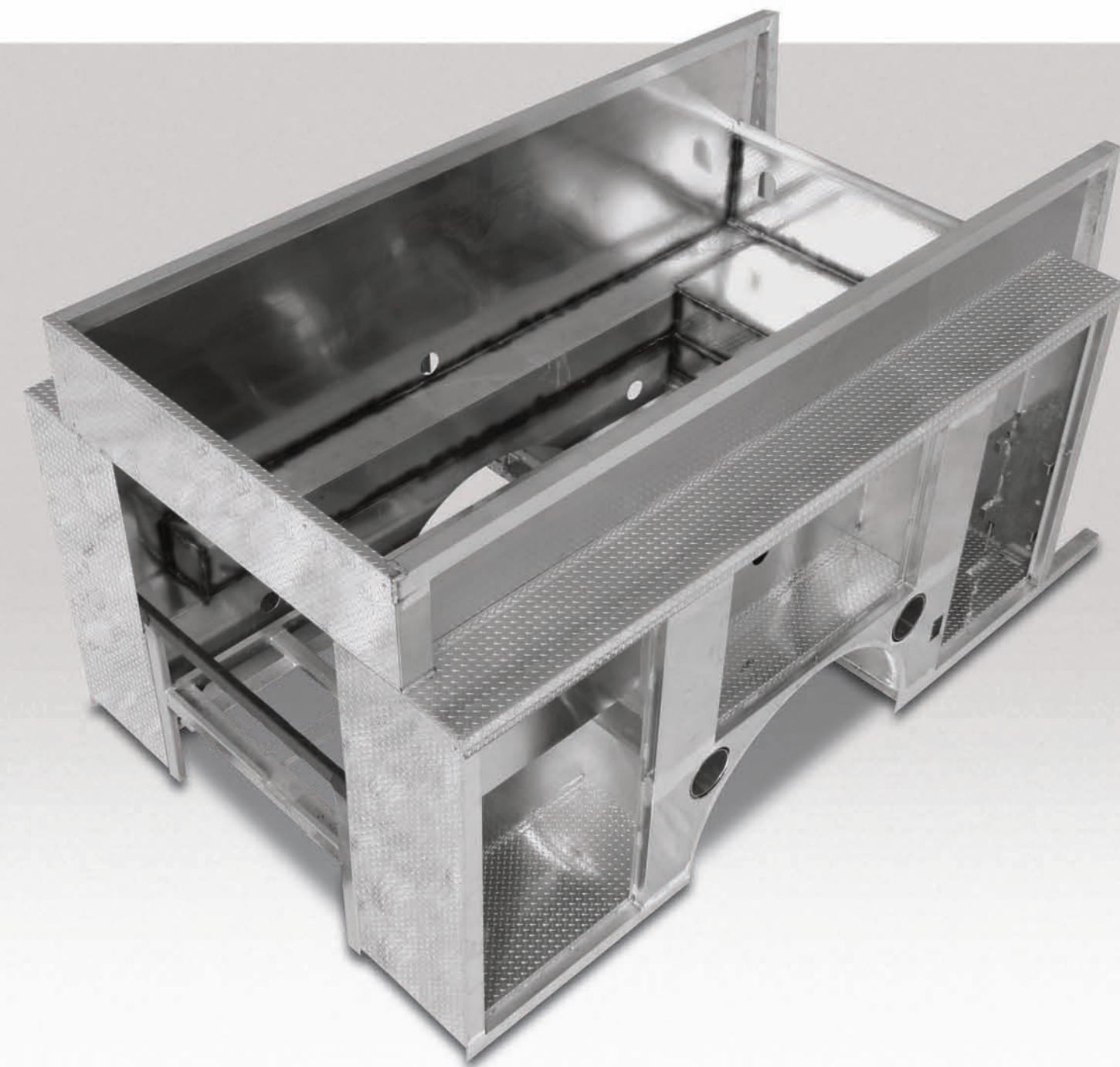

SOUTH DAKOTA DIVISION
100 THIRD STREET
LYONS, SOUTH DAKOTA 57041
P: 605.543.5591

MINNESOTA DIVISION
5181 260TH STREET
WYOMING, MINNESOTA 55092
P: 651.462.1000

AERIALS DIVISION
870 SOUTH BROAD STREET
FREMONT, NEBRASKA 68025
P: 402.721.7622

SALES DIVISION
P: 605.543.5551
E: info@rosenbaueramerica.com

ROSENBAUER



Aerial



Commercial Tanker



Custom Pumper

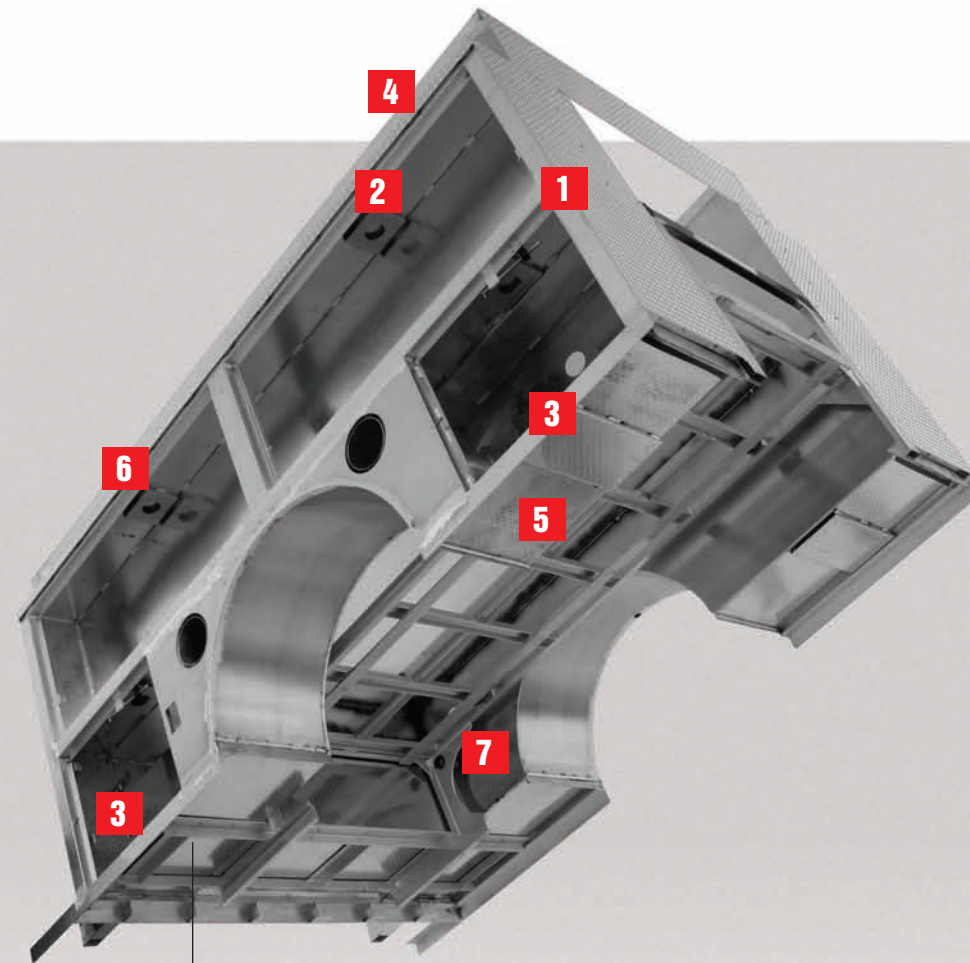

Lifetime Warranty

Rosenbauer FX body styles offer a galvanized subframe with a lifetime warranty.

Heavy-Duty Steel Subframe

Heavy-duty steel tube, channel, angles and gussets are welded together and hot-dip galvanized to form an extremely strong subframe, which is the backbone of this modular body. It is built using formed sheets and heavy duty extrusions.

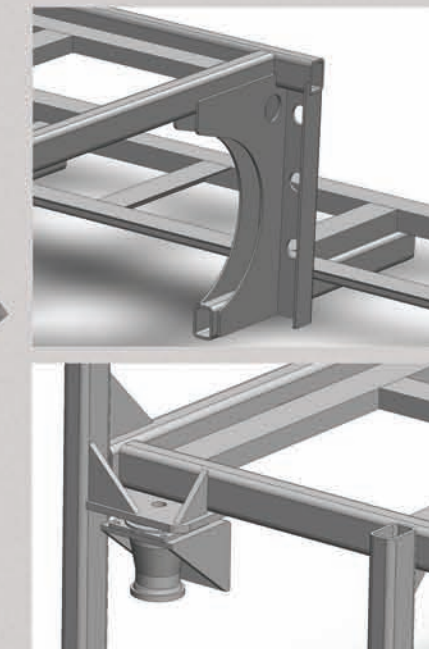

The optional extreme duty subframe features extra heavy wall steel tubing and double plate steel gussets at the rear. The front is mounted using a specially designed metacone rubber mounting system to absorb road shock and twisting forces.

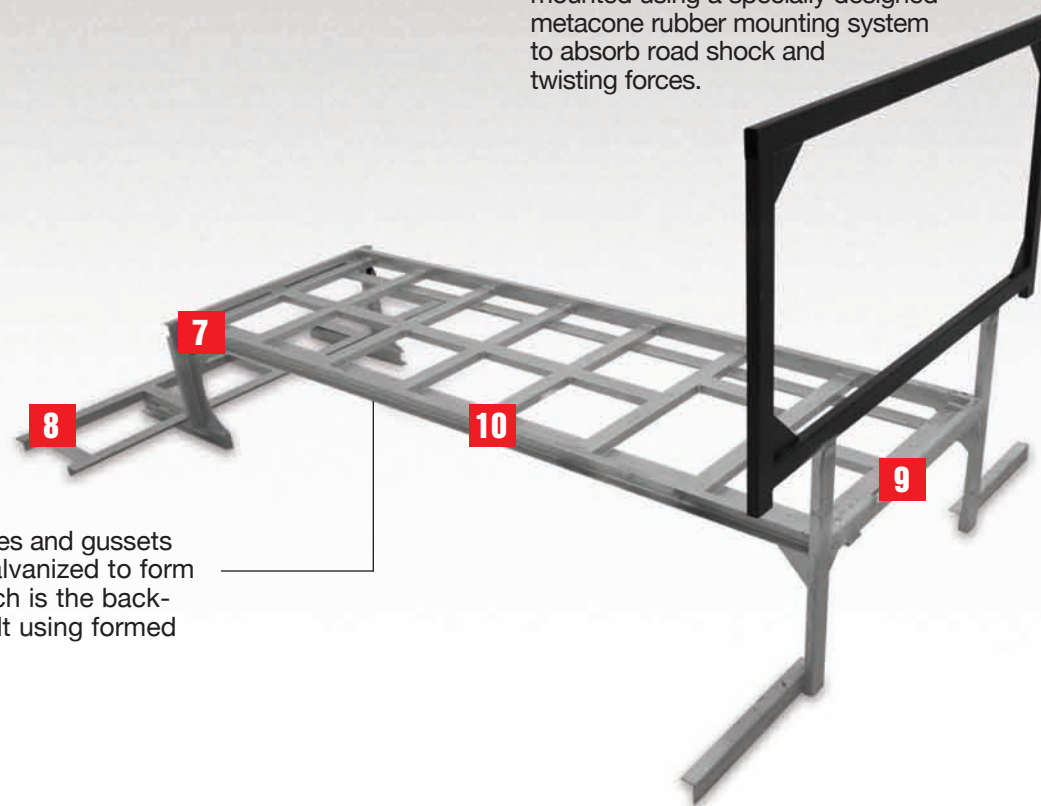

1
Front and Back Door Post Extrusion



2
Top and Intermediate Door Frame Extrusion



3
Angled Aluminum Body Support Extrusion

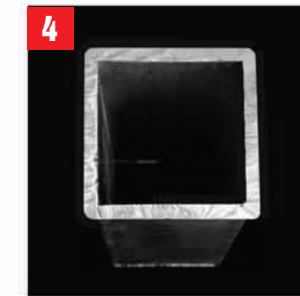

4
Main Framing Extrusion

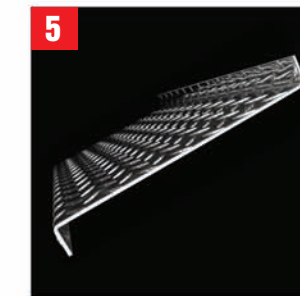

5
.125" Interior Diamond Plate
(.190" Optional)

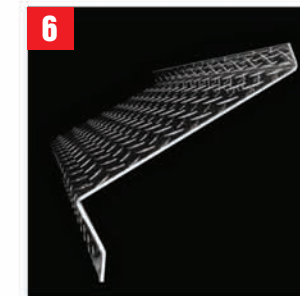

6
.125" Diamond Plate Top Cap
(.190" Optional)



7
Flat Gusset Plate
(.375" Steel)



8
Angled Body Outrigger
(2" x 3")

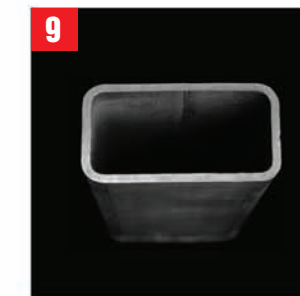

9
Steel Tubing
(1.75" x 3")



10
Subframe Channel
(1.75" x 3")



Space for your largest equipment

Flush-mounted hinged doors with stainless steel hardware allow full-width storage. Compartments can also be customized to fit your needs with shelves, roll-out trays and equipment mounts.



Doors designed for safety and convenience

Roll-up doors give you easy access to adjustable shelves, roll-out trays and tool boards without extending into the roadway for added safety.



Wiring you can rely on

Heavy gauge function and color-coded wiring along with resetting circuit breakers and junction strips form the basis for a reliable wiring system. Multiplexing optional.



Detailed, precise paint application

Rosenbauer's state-of-the-art paint process is environmentally controlled for precise application. Paint is mixed to create or match any shade and then applied and baked for a durable, consistent, high-gloss finish.