

# FIRESTAR

EXT Custom Pumper



Pre-Engineered to Save you Time and Money.  
Unit shown may have optional equipment.



**Designed for quick delivery, this unit is a base model with a wide variety of pre-packaged options. The Firestar Series, with pre-engineered options, can be designed to meet your department's needs.**

## Custom Chassis

- » Spartan Custom Chassis
- » Four Door Custom Cab with Raised Roof
- » 380 Hp Engine
- » 3000 Series Allison Automatic Transmission
- » 270 Amp Alternator
- » 18,000 lb. Front Axle
- » 24,000 lb. Rear Axle
- » ABS Braking System (Air)
- » Engine Brake
- » Combination Air Conditioner/Heater
- » 57,600 BTU Overhead Mounted Heater
- » SCBA Officer's Seat
- » Two-Way Gray Seat both Driver and Operator
- » Two Outboard SCBA Rear Facing Seats
- » Two Forward-Facing SCBA Seats
- » Seat Belt Warning System
- » Vehicle Data Recorder (VDR)
- » 18.7 CFM Air Compressor

## Body

- » EXT Body with Lifetime Body Warranty Style 1
- » 1250 GPM Single Stage Pump (Darley, Hale or Waterous)
- » Stainless Steel Plumbing
- » Electronic Governor/Gauge Package
- » 1000 Gallon Poly Tank
- » Stainless Steel Plumbing
- » Side Mount Pump Controls
- » Brushed Stainless Steel Pump Panel
- » Two 6" Inlets
- » One 2-1/2" Left Side Inlet
- » One 2-1/2" Left Side Discharge
- » One 2-1/2" Right Side Discharge
- » One 3" LDH Right Side Discharge
- » One 2-1/2" Right Side Rear Discharge
- » Two 1-3/4" Crosslays with 2" Piping
- » Aluminum Crosslay Cover
- » Vinyl Hosebed Cover
- » 3" Tank to Pump
- » 2" Tank Refill Line
- » Color Coded Pump Panel Tags
- » Liquid Filled Gauges
- » Roll-up Doors with Natural Finish
- » High Left Side Compartments
- » Low Right Side Compartments
- » Rear Transverse Compartment
- » Ladder Mounts for Right Side (above Low Compartment)
- » 4" Reflective Stripe (White)
- » Chevron Style Reflective Striping (on the Rear Body Face)
- » Whelen LED Lower Light Package (Including Tail Lights)
- » Whelen LED Light Bar w/ Halogen Upper Rear Rotators
- » Whelen Siren Package

**Price:** \$ \_\_\_\_\_

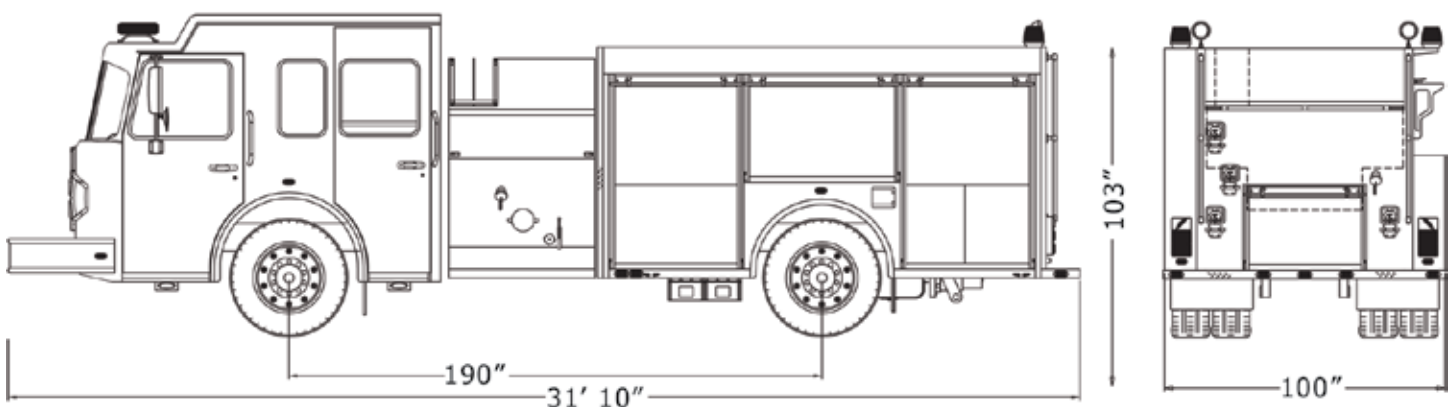

# OPTIONS

<input type="checkbox"/> Upgrade chassis to 400 hp	\$ _____	<input type="checkbox"/> 2-1/2" right side inlet	\$ _____
<input type="checkbox"/> Aluminum body (EXT style):		<input type="checkbox"/> Additional 2-1/2" left side discharge	\$ _____
<input type="checkbox"/> Style 2 (full height each side/split depth)	\$ _____	<input type="checkbox"/> Additional 2-1/2" right side discharge	\$ _____
<input type="checkbox"/> Style 3 (full height ea. side/full depth; only avail. w/ 500 or 750 tank)	\$ _____	<input type="checkbox"/> 2-1/2" hosebed preconnect	\$ _____
<input type="checkbox"/> Painted roll-up doors	\$ _____	<input type="checkbox"/> Extended bumper with 1-3/4" preconnect	\$ _____
<input type="checkbox"/> Hinged doors	\$ _____	<input type="checkbox"/> 6" front suction (with bumper extension)	\$ _____
<input type="checkbox"/> Full height rear compartment (with roll-up door)	\$ _____	<input type="checkbox"/> Direct tank fill 2-1/2" at rear of body	\$ _____
<input type="checkbox"/> Wheel well compartments (aluminum & SS body only):		<input type="checkbox"/> 2-1/2" crosslay	\$ _____
<input type="checkbox"/> Extinguisher	\$ _____	<input type="checkbox"/> 3" deck gun provision	\$ _____
<input type="checkbox"/> Three SCBA Bottles (Fire Shopp BSST)	\$ _____	<input type="checkbox"/> Booster reel (with 150' of 1" hose at rear of truck)	\$ _____
<input type="checkbox"/> Alum. tool boards (rear wall) Qty: _____ x \$ _____	\$ _____	<input type="checkbox"/> Top mount pump control panel	\$ _____
<input type="checkbox"/> Adjustable shelves Qty: _____ x \$ _____	\$ _____	<input type="checkbox"/> Upgrade third party pump test to the ULC package	\$ _____
<input type="checkbox"/> Roll-out trays Qty: _____ x \$ _____	\$ _____	<input type="checkbox"/> Two hard suction carriers	\$ _____
<input type="checkbox"/> Roll-out tool boards Qty: _____ x \$ _____	\$ _____	<input type="checkbox"/> Code 3 LED light package	N/C
<input type="checkbox"/> Swing-out tool boards Qty: _____ x \$ _____	\$ _____	<input type="checkbox"/> Federal Signal LED light package	\$ _____
<input type="checkbox"/> Compartment vents	\$ _____	<input type="checkbox"/> Honda 5 kW generator (with two 500 Watt telescoping lights)	\$ _____
<input type="checkbox"/> SCBA brackets (5 - with custom chassis only)	\$ _____	<input type="checkbox"/> 8 kW hydraulic generator (with two 500 Watt telescoping lights)	\$ _____
<input type="checkbox"/> Wheel trim package	\$ _____	<input type="checkbox"/> Green Star ABP two-battery system	\$ _____
<input type="checkbox"/> Additional hosebed height	\$ _____	<input type="checkbox"/> Cold weather package (heat pan and pump comp. heater)	\$ _____
<input type="checkbox"/> Hosebed dividers Qty: _____ x \$ _____	\$ _____	<input type="checkbox"/> Air compressor (with battery charger and auto eject)	\$ _____
<input type="checkbox"/> Aluminum hosebed cover	\$ _____	<input type="checkbox"/> Air horns	\$ _____
<input type="checkbox"/> Pump choices: (1250 GPM)		<input type="checkbox"/> Equipment package (incl. one 24' extn. ladder, one 14' roof ladder, \$ _____	
<input type="checkbox"/> Hale		<input type="checkbox"/> Darley	
<input type="checkbox"/> Darley 1500 GPM (in place of 1250 GPM)	\$ _____	<input type="checkbox"/> Waterous	N/C
<input type="checkbox"/> Waterous 1500 GPM (in place of 1250 GPM)	\$ _____		
<input type="checkbox"/> Rosenbauer NH 55 (1250 GPM with pump-and-roll, HP booster hose reel & HP Fix-Mix foam system)	\$ _____	<input type="checkbox"/> Rosenbauer EZ Climb ladder (in place of rear steps)	\$ _____
<input type="checkbox"/> Rosenbauer NH 55 (1250 GPM with pump-and-roll, HP front monitor, HP booster hose reel & HP Fix-Mix foam system)	\$ _____	<input type="checkbox"/> Apparatus color: <input type="checkbox"/> Red <input type="checkbox"/> White	N/C
<input type="checkbox"/> Foam Pro 1600 foam system (with 20 gallon tank)	\$ _____	<input type="checkbox"/> Custom single tone color (color code: _____)	N/C
<input type="checkbox"/> Foam Pro 2001 foam system (with 20 gallon tank)	\$ _____	<input type="checkbox"/> Two tone paint (upper is white; lower code: _____)	\$ _____
<input type="checkbox"/> Foam Pro 2002 foam system (with 20 gallon tank)	\$ _____	<input type="checkbox"/> Lettering	\$ _____
<input type="checkbox"/> Rosenbauer EZ Foam	\$ _____	<input type="checkbox"/> Reflective striping	
<input type="checkbox"/> 500 – 750 gallon tank IPO 1000 gallon tank	N/C	<input type="checkbox"/> 4" S design	\$ _____
<input type="checkbox"/> Top mount control for 2-1/2" inlet	\$ _____	<input type="checkbox"/> 6" S design	\$ _____
		<input type="checkbox"/> 4" Z design	\$ _____
		<input type="checkbox"/> 6" Z design	\$ _____
		<input type="checkbox"/> Special Striping	\$ _____

**Total Options Cost:** \$ \_\_\_\_\_

Prices valid through 12/31/11

## Style 1



## Style 2



## Style 3



South Dakota Division  
100 Third Street  
Lyons, SD 57041  
605.543.5591

Minnesota Division  
5181 260th Street  
Wyoming, MN 55092  
651.462.1000

Aerials Division  
870 South Broad Street  
Fremont, NE 68025  
402.721.7622

Sales Division  
605.543.5591  
[info@rosenbaueramerica.com](mailto:info@rosenbaueramerica.com)